



# **HUNTER'S MEAT CUTTING SAW**

## **MODEL G1016**

### **INSTRUCTION MANUAL**



COPYRIGHT © 1995 BY GRIZZLY IMPORTS, INC.

**WARNING: NO PORTION OF THIS MANUAL MAY BE REPRODUCED IN ANY SHAPE OR FORM WITHOUT THE WRITTEN APPROVAL OF GRIZZLY IMPORTS, INC.**

JULY, 1995. PRINTED IN USA

**DISCONTINUED MACHINE MANUAL DISCLAIMER**

THE INFORMATION IN THIS MANUAL REPRESENTS THE LAST CONFIGURATION OF THE MACHINE BEFORE IT WAS DISCONTINUED. MACHINE CONFIGURATIONS MAY HAVE CHANGED AS PRODUCT IMPROVEMENTS WERE INCORPORATED. IF YOU OWN AN EARLIER VERSION OF THE MACHINE, THIS MANUAL MAY NOT EXACTLY DEPICT YOUR MACHINE. CONTACT CUSTOMER SERVICE IF YOU HAVE ANY QUESTIONS ABOUT DIFFERENCES. PREVIOUS VERSIONS ARE NOT AVAILABLE ONLINE.

---

# Table of Contents

	<b>PAGE</b>
<b>I. Introduction</b> .....	1
<b>II. Safety Rules for all Tools</b> .....	2
<b>III. Electrical Requirements</b> .....	4
A. Circuit Loading.....	4
B. Grounding .....	4
C. General Information.....	4
D. Word of Caution .....	4
<b>IV. Site Planning</b> .....	5
A. Working Clearances .....	5
B. Lighting and Outlets .....	5
<b>V. Unpacking</b> .....	5
<b>VI. Piece Inventory</b> .....	6
<b>VII. Assembly</b> .....	7
A. Stand .....	7
B. Motor .....	8
C. Bandsaw Unit .....	8
D. Pulleys and V-Belt .....	9
E. Table .....	10
F. Fence and Guards.....	10
G. Meat Grinder .....	11
H. Stand Enclosures .....	11

# Table of Contents

---

## PAGE

<b>VIII. Adjustments</b> .....	12
A. Blade Tension .....	12
B. Tracking .....	13
C. Guide Blocks .....	14
D. Support Bearings .....	15
E. Blade Removal and Replacement .....	16
F. Blade Guard .....	16
<b>IX. Safety Rules for Bandsaws</b> .....	17
<b>X. Operations</b> .....	18
A. General .....	18
B. Test Run .....	18
C. Cutting Procedures .....	18
D. Meat Grinder .....	18
<b>XI. Cleaning</b> .....	19
<b>XII. Maintenance</b> .....	20
A. Lubrication .....	20
B. Miscellaneous .....	20
<b>XIII. Troubleshooting</b> .....	21
<b>XIV. Machine Data</b> .....	22
<b>XV. Main Parts Diagram</b> .....	23
<b>XVI. Meat Grinder Parts Diagram</b> .....	24
<b>XVII. Stand Parts Diagram</b> .....	25
<b>XVIII. Parts List</b> .....	26
<b>XIX. Warranty and Returns</b> .....	BACK COVER

---

# I. Introduction

We are proud to offer the Hunter's Meat Cutting Bandsaw. When used according to the guidelines stated in this manual, you can expect years of trouble-free, enjoyable operation and experience proof of our commitment to customer satisfaction.

The saw features a sheet steel body, easy to clean stainless steel table, and a 10<sup>1</sup>/<sub>4</sub>" cutting height. It comes equipped with a 1720 RPM, 1 HP motor.

We are also pleased to provide this manual with your saw. It was written to guide you through assembly, review safety considerations, and cover general operating procedures. It represents our latest effort to produce the best documentation possible. If you have any criticisms that you feel we should pay attention to in our next printing, please write to the customer service address listed on your catalog: attn: Manager, Technical Documentation.

Most importantly, we stand behind our machines. If you have any service questions or parts requests, please call or write us at the appropriate customer service location listed on your catalog.

To operate this or any power tool safely and efficiently, it is essential to become as familiar with its characteristics as possible. Take as much time as necessary to become acquainted with your saw. The time you invest before you begin to use your machine will be time well spent. Also, read all of the safety procedures. If you do not understand something about this machine, **DO NOT** operate it.

The specifications, drawings, and photographs illustrated in this manual represent the Hunter's Meat Cutting Bandaw as supplied when the manual was prepared. However, owing to our policy of continuous improvement, changes may be made at any

time with no obligation on our part. Whenever possible, though, we send manual updates to all owners of a particular tool or machine. Should you receive one, we urge you to insert the new information with the old and keep it for reference.

The information in this manual has been obtained from sources we believe to be reliable and as up-to-date as possible. We have included some important safety measures which we believe to be essential for safe operation. While most safety measures are generally universal, we remind you that each work area is different and safety rules should be considered *as they apply to your specific situation*. Also – please read the entire manual before attempting to operate your saw.

We recommend that you keep a copy of our current catalog for complete information regarding our warranty and return policy. Should you need additional technical information relating to this machine, or if you need general assistance or parts, please contact the customer service department.

We also believe additional information sources are very important for reaping the full potential of this machine. Consulting with your local butcher would be a good place to start.

**WARNING!** This saw is dangerous. Use the tool with respect and caution to lessen the possibility of mechanical damage or injury. If normal safety precautions are overlooked or ignored, injury to the operator or others in the area is likely.

This bandsaw was specifically designed for meat cutting. ***Modifications or improper use of this tool will void the warranty.*** If you are confused about any aspect of this machine, **DO NOT** use it until you have resolved any questions you have.

---

End of Section

## II. Safety Rules for all Tools

---

- 1. KNOW YOUR POWER TOOL.** Read the owner's manual carefully. Learn the tool's applications and limitations, as well as its hazards.
- 2. KEEP ALL GUARDS IN PLACE** and in working order.
- 3. GROUND ALL TOOLS.** If an adapter is used to accommodate a two-prong receptacle, the adapter plug must be attached to a known ground. Never remove the grounding prong.
- 4. REMOVE ADJUSTING KEYS AND WRENCHES.** Make it a habit to check that keys and wrenches are removed from the machine before turning it on.
- 5. KEEP WORK AREA CLEAN.** Cluttered areas and benches invite accidents.
- 6. AVOID DANGEROUS ENVIRONMENTS.** Keep your work area well lighted.
- 7. KEEP CHILDREN AND VISITORS AWAY.** All children and visitors should be kept a safe distance away from your work area.
- 8. MAKE WORK AREA CHILD-PROOF** with padlocks, master switches, or by removing starter keys.
- 9. DO NOT FORCE TOOL.** Tools work better and more safely when they are allowed to work at their own speed.
- 10. USE THE RIGHT TOOL.** Do not use a tool or an attachment to do a job that it was not intended to perform.
- 11. WEAR PROPER APPAREL.** Do not wear loose clothing, gloves, neckties, or jewelry that might get caught in moving parts. Non-slip footwear is also recommended. Wear a hat or other protective head wear if your hair is long.
- 12. USE SAFETY GLASSES AND EAR PROTECTION.**
- 13. DO NOT OVERREACH.** Keep proper footing and balance at all times.
- 14. MAINTAIN TOOLS IN TOP CONDITION.** Keep tools sharp and clean for best and safest performance. Follow instructions for lubricating and changing accessories.
- 15. DISCONNECT TOOLS FROM POWER** before servicing and when changing accessories.
- 16. USE ONLY RECOMMENDED ACCESSORIES.** Consult the current catalog for recommended accessories. Using improper accessories may be hazardous.
- 17. AVOID ACCIDENTAL STARTING.** Make sure the switch is in the "OFF" position before plugging in the cord.

---

## II. Safety Rules for all Tools

**18. NEVER STAND OR LEAN ON TOOL.** Serious injury could occur if the tool is tipped or if the cutting edge is accidentally contacted.

**19. CHECK DAMAGED PARTS.** Before further use of the tool, any part or guard that is damaged should be promptly repaired or replaced. Do not operate the machine until you are certain that it is in perfect running condition. Failure to follow this precaution could result in further mechanical damage and operator injury.

**20. DO NOT WORK IN HASTE** or operate machine if you are mentally or physically fatigued.

**21. NEVER LEAVE THE TOOL RUNNING UNATTENDED - TURN POWER OFF.** Do not leave the tool until it comes to a full stop.

**22. DO NOT OPERATE THE TOOL UNDER THE INFLUENCE OF DRUGS, ALCOHOL, OR MEDICATION.** Never operate machinery when overly fatigued.

**23. IF THERE IS SOMETHING YOU DO NOT KNOW OR UNDERSTAND ABOUT THIS MACHINE, DO NOT OPERATE IT!** Ask for help first. Confusion is dangerous.

**24. BAD HABITS ARE DANGEROUS.** Review all safety procedures often.

These safety rules, while expansive, may not cover every situation. Please consider your unique conditions when setting up and using your saw.

More safety rules are reviewed in **Section IX.**

---

End of Section

***Remember:  
Safety First!***

## III. Electrical Service Requirements

---

When placing the bandsaw in your work area, three considerations should be addressed; electrical service requirements, working clearances, and lighting and outlets. We'll look at the first consideration now and leave the other two for the next section.

The bandsaw has a 1 HP motor which is ready for 110V, single phase operation.

You must wire the motor to the switch.

---

### A. Circuit Loading

The motor will safely draw about 12 amps at 110V under load. If you operate the bandsaw on any circuit that is already close to its capacity, it might blow a fuse or trip a circuit breaker. However, if an unusual load does not exist, and power failure still occurs, have the circuit inspected by a qualified electrician.

**CIRCUIT BREAKERS/FUSES:** A 15 amp circuit breaker or fuse should be used for a 110V undedicated circuit. The general rule is to use the lightest breaker or fuse that will hold under regular loads. Circuit breakers or fuses that are rated higher may not adequately protect the motor.

### B. Grounding

**This machine must be electrically grounded.** We have furnished the bandsaw with a plug suitable for use with a grounded, domestic 110V circuit.

Please verify that any circuit you intend to use is actually grounded. If the circuit is not grounded, it will be necessary to run a separate 12 AWG copper grounding wire from the machine frame to a grounding terminal in your electric service panel. Consult with a licensed electrician if you are unsure about machine grounding.

*If you are unsure about connecting your bandsaw, don't take chances: consult the service dept or a licensed electrician.*

**EXTENSION CORDS:** If used, extension cords must be rated hard service – grade S – or better. Conductor size must be 12 AWG for cords up to 50 feet in length. Your extension cord must also contain a ground wire and plug pin. Repair or replace extension cords if they become damaged.

### C. Word of Caution

In this section we have covered some basic electrical requirements for the safe operation of your bandsaw. As with the safety rules in the preceding section, these requirements are not necessarily comprehensive. Further, you must be sure that your particular electrical configuration complies with local and state codes. The best ways to ensure compliance are to check with your local municipality or licensed electrician.

---

End of Section

---

## IV. Site Planning

### A. Working Clearances

Be sure that there is plenty of room around your saw before cutting. Relocate any items that risk contamination and cannot be easily washed. Allow yourself sufficient room to run your saw **IN ANY FORESEEABLE OPERATION.**

### B. Lighting and Outlets

Lighting should be bright enough to eliminate shadow and prevent eye strain. Electrical circuits should be dedicated or large enough to handle combined motor amp loads. Outlets should be located near the machine so power or extension cords are not obstructing high-traffic areas. Be sure to observe local electrical codes for proper installation of new lighting, outlets, or circuits.

---

End of Section

---

## V. Unpacking

The bandsaw is shipped from the factory in a carefully packed carton. If you find the machine to be damaged after you've signed for delivery and the truck and driver are already gone, you will need to file a freight claim with the carrier. Save the containers and all packing materials for inspection by the carrier or their agent. Without the packing materials, filing a freight claim can be difficult. If you need advice regarding this situation, please call us immediately.

**Caution:** The meat cutting saw is a **HEAVY** machine (106 lbs. shipping weight). **DO NOT** over-exert yourself while unpacking or moving your machine – get assistance. In the event that your bandsaw must be moved up or down a flight of stairs, be sure that the stairs are capable of supporting the combined weight of people and the machine.

When you are completely satisfied with the condition of your shipment, you should inventory its parts.

---

End of Section



## VI. Piece Inventory

---

**With all the parts removed from the container, you should have:**

- Bandsaw Unit with Blade
- Motor
- Motor Pulley
- V-Belt
- Table
- Fence
- Column Guard
- Blade Guard
- Table & Guard Knobs (13)
- Stand Parts (5)
- Stand Enclosures (2)
- Motor Mounting Brackets (2)
- Meat Grinder
- Plastic Pestle
- Casing Tube
- Fasteners

If anything is missing, call or write the customer service department. If anything is damaged, please follow the procedures described in **Section V** above.

Below is a list of fasteners required to assemble your bandsaw. If any standard hardware is missing (e.g., a nut or bolt), we will be happy to replace it, but it would be quicker to buy replacements from your local hardware store. However, if an unusual amount of fasteners or proprietary parts are missing, please let us know. A full parts list and breakdown can be found toward the end of this manual.

<u>QTY.</u>	<u>DESCRIPTION</u>	<u>LOCATION</u>
22	$\frac{5}{16}$ " - 18 x $\frac{5}{8}$ " Carriage Bolts	Stand
30	$\frac{5}{16}$ " - 18 Hex Nuts	Stand
34	$\frac{5}{16}$ " Flat Washers	Stand
4	Foot Assemblies	Stand
4	$\frac{5}{16}$ " - 18 x $\frac{3}{4}$ " Hex Bolts	Motor
3	$\frac{3}{8}$ " - 16 Threaded Studs	Stand/Bandsaw Body
4	90° Brackets	Stand

**Figure 1** shows the bolt bag contents.

---

**End of Section**

## VII. Assembly

### A. Stand

**Note:** All die-cut metal parts have a sharp edge (called “flashing”) on them after they are formed. This is removed at the factory. Sometimes, though, a bit of flashing might escape inspection. Please examine the edges of all die-cut metal parts before handling them.

**TOOLS REQUIRED:** Common hand tools are necessary to assemble this machine. You will need a set of open ended metric and standard wrenches and a Phillips head screwdriver.

1. Flip the top of the stand upside down and place it on your benchtop.
2. Attach the sides using the carriage bolts, washers, and nuts provided. Mount the stand front (the side with the switch) so it is on the same side as the rectangular hole in the stand top. **Figure 2.** Do not fully tighten the nuts.
3. Mount the braces between the front and back panels. Use carriage bolts, washers, and nuts provided. Tighten partially.
4. Press the 90° brackets onto the bottom corners of the stand. These are stiffeners.

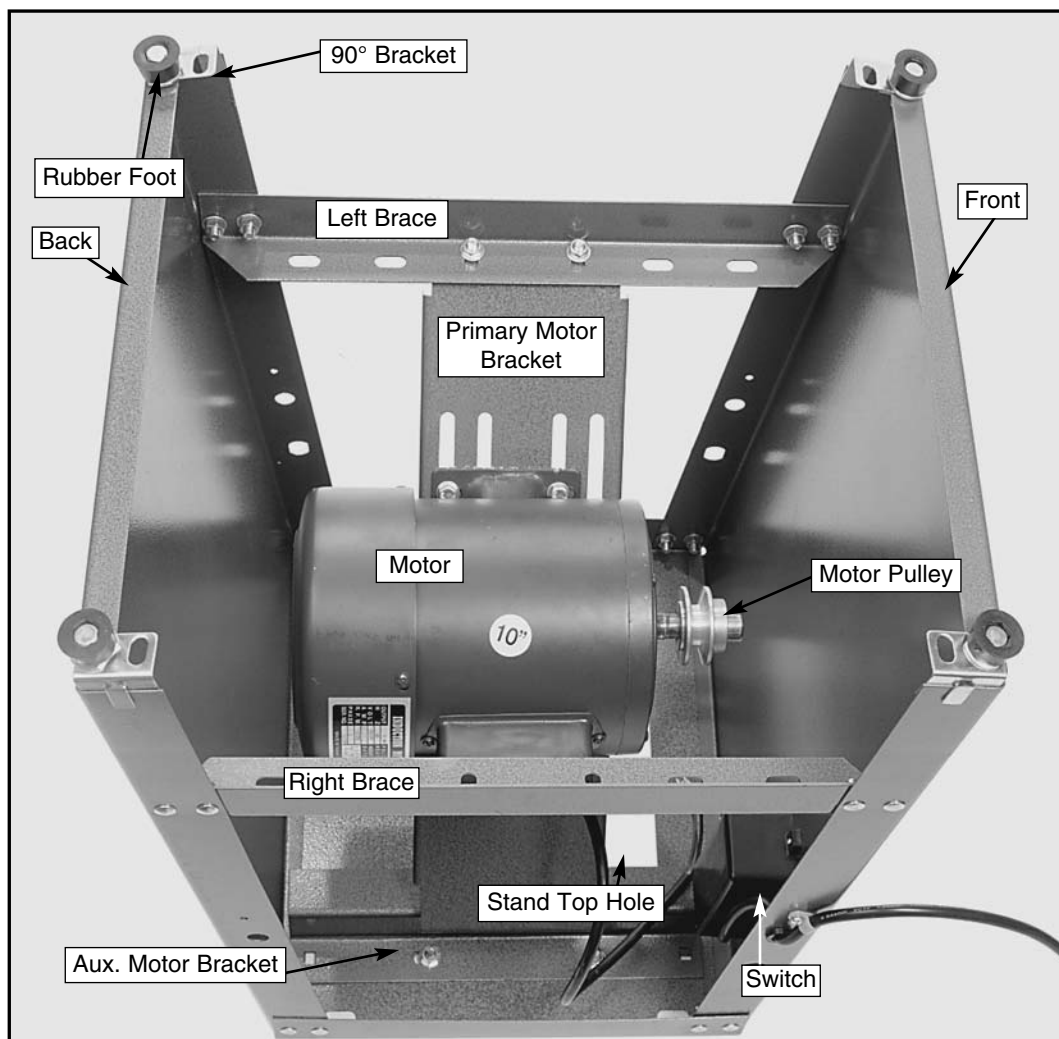

**Figure 2** shows the stand/motor assembly completed.

5. Install the rubber feet. They should go through the 90° brackets first and then through the sides. Tighten securely.

### B. Motor

1. Secure the auxiliary motor bracket to the stand top. Use carriage bolts, nuts, and washers. **Figure 2.**
2. Fasten the primary motor bracket to the left brace and the auxiliary motor bracket. Use carriage bolts, nuts, and washers. Do not fully tighten.
3. Mount the motor to the primary motor bracket using the hex bolts, nuts, and washers provided. Do not fully tighten.
4. Press the motor pulley over the motor shaft and insert the key in the keyway. Position the pulley so its V-groove is roughly centered over the rectangular slot in the stand top. *Tolerances are tight: you may need to sand the key or the keyways slightly.* Tighten the setscrew.
5. Now that the motor is mounted, tighten all the stand bolts but leave the motor bolts loose.
6. Flip the stand/motor assembly right side up on the floor. Hold the motor so it does not slide when you tip the stand over.

7. If the stand is wobbly, check your floor first. If the floor is level, loosen the bolts and wiggle the stand until it rests firmly on the floor. Re-tighten the bolts.

### C. Bandsaw Unit

1. Lift the bandsaw onto the stand. The front of the saw must be on the same side as the switch.
2. Attach the bandsaw to the stand with the three (3) threaded studs. Screw them up through the stand top and into the welded nuts on the base of the bandsaw. **Figure 3.** *It may be necessary to shift the bandsaw slightly to get the studs lined up right.*
3. Feed the short electrical cord through the plastic wire clamp in the motor junction box. Connect the wire according to the wire diagram insert included with this manual. Tighten the wire clamp. **DO NOT** over-tighten – the plastic threads may strip.
4. The longer cord from the base of the saw is the power cord. It is prefitted with a 110V grounded plug. **NEVER REMOVE THE GROUNDING PRONG!**

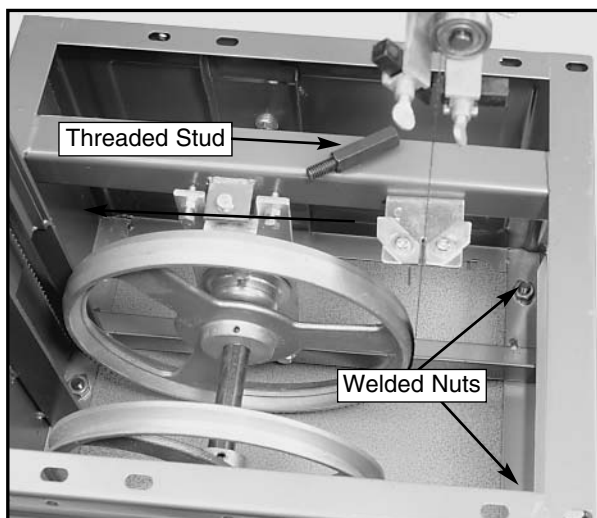

**Figure 3** shows the stud mounting locations.

**D. Pulleys and V-Belt**

Pulley alignment and proper V-Belt tension are crucial to increased belt life and optimal power transmission from motor to blade.

The motor pulley should already be centered under the slot in the stand top. Shift the driven pulley so it lines up with the motor pulley.

**To align the driven pulley (Figure 4):**

1. Loosen the setscrew on the back of the driven pulley.
2. Grasp the pulley on the top and bottom. Shift it along its shaft to line up the V-grooves on both pulleys. Use sight to judge their vertical alignment.
3. Tighten the setscrew on the driven pulley.

**To install and properly tension the V-Belt:**

1. Push the motor up to the top of its slots.
2. While holding the motor in place, slip the V-Belt into the grooves in the pulleys.
3. Slide the motor down until the V-Belt is properly tensioned. You should be able to deflect the belt about 1" at the midpoint. Use moderate finger pressure. **Figure 5.**
4. Check that the motor pulley is still in line with the driven pulley. *The motor will have a tendency to twist slightly when it is moved. This will push the pulleys out of alignment and twist the V-Belt. Check and adjust motor position if twisting occurs.*
5. Tighten the motor mounting bolts.

When cleaning (**Section XI**), you will need to take off and put on the V-Belt. This can be done without adjusting the position of either

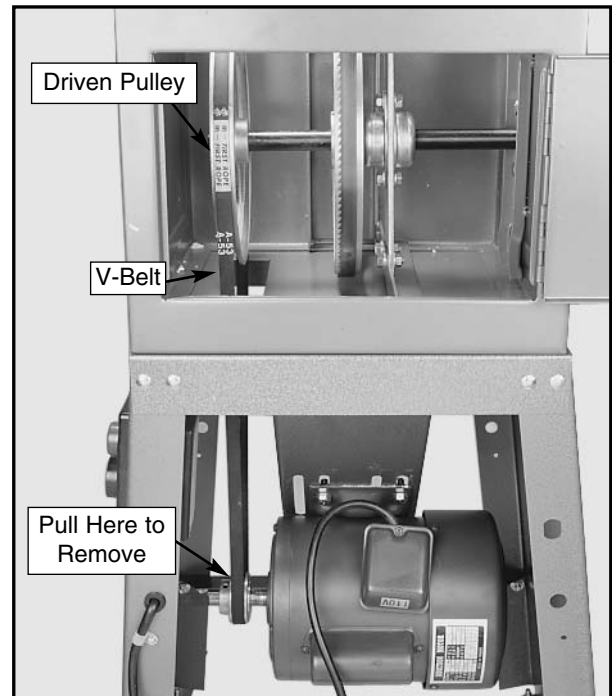

**Figure 4** shows the V-Belt installed correctly.

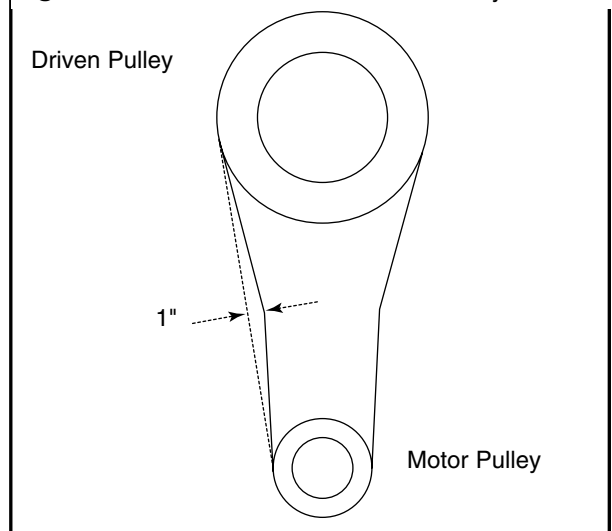

**Figure 5** shows proper V-Belt deflection.

pulley. **UNPLUG THE MACHINE FIRST!** To remove the V-Belt, pull it laterally from the back of the motor pulley and roll the pulleys forward. The belt will pop off. **Figure 4.**

**To replace the V-Belt,** loop it over the motor pulley and as much of the driven pulley as possible. Roll the pulleys forward and the V-belt will slip into the grooves, just like a bicycle chain on its sprockets.

## E. Table

**Before installing the table and guards, peel off the blue, protective plastic.**

Slide the table on at a 45° angle. **Figure 6.** Lower the table so the notch goes around the column. When it is in its final position, secure it to the bandsaw body using the black knobs provided.

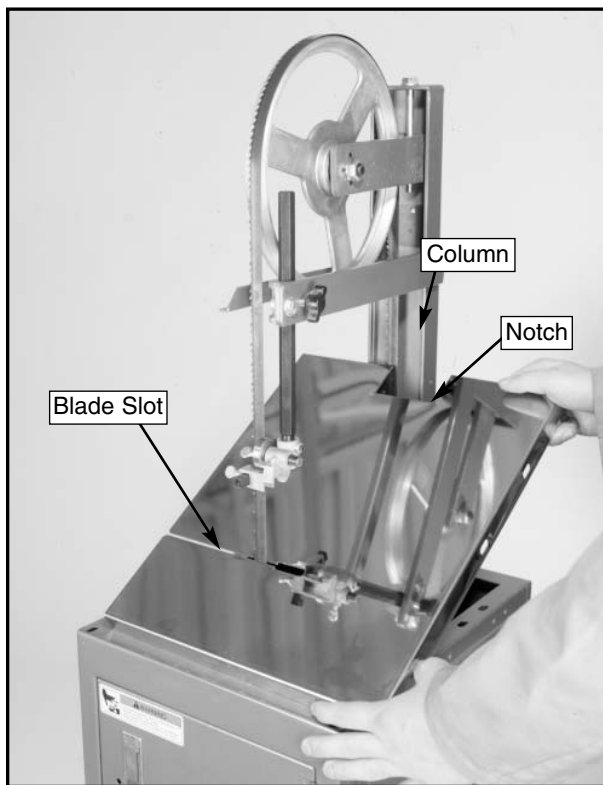

**Figure 6** shows how to install the table.

## F. Fence & Guards

### Fence:

Install the fence so the vertical portion is facing the blade. **Figure 7.** Secure it to the table and bandsaw body with the black knobs.

### Column Guard:

Attach the column guard to the vertical column. Use the black knobs. **Figure 7.**

### Upper Wheel Guard:

Attach the upper wheel guard to the vertical column using a black knob. **Figure 7.**

### Blade Guard:

Using the last 2 black knobs, secure the blade guard to the upper wheel guard. *You may need to place washers behind the heads of the knobs so the threaded ends do not touch the blade. Extra washers are not provided.* **Figure 7.**

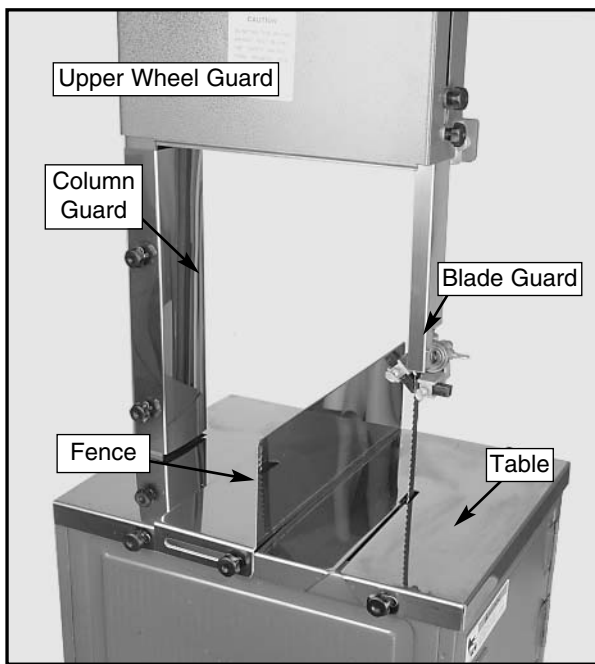
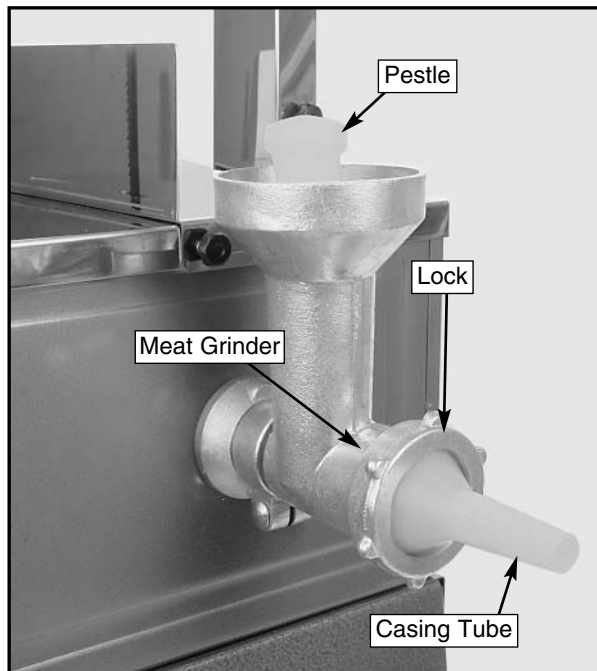

**Figure 7** shows the fence, guards, and table installed correctly.

**G. Meat Grinder****To install the meat grinder (Figure 8):**

1. Loosen the mounting bolt at the base of the meat grinder.
2. Line up the tang on the saw with the slot on the grinder (similar to a flat head screwdriver and a screw).
3. Push the meat grinder on the aluminum holder. *Some twisting and turning may be necessary to slide it on; it is a tight fit.*
4. Put the die in place and screw down the lock. Re-tighten the mounting bolt.

***If you don't intend to grind meat, don't leave the grinder on the bandsaw. Meat juices are its lubrication and running dry will cause excessive wear.***



**Figure 8** shows the meat grinder installed with the casing tube in place.

**H. Stand Enclosures****To install the stand enclosures:**

1. Attach 6 plastic tabs to each plastic enclosure using the screws provided. *Tighten them so they can still be turned by hand, without further adjustment with a screwdriver.* **Figure 9.**
2. Position each stand enclosure as shown in **Figure 9**. Turn the plastic tabs so they keep the enclosures in place.

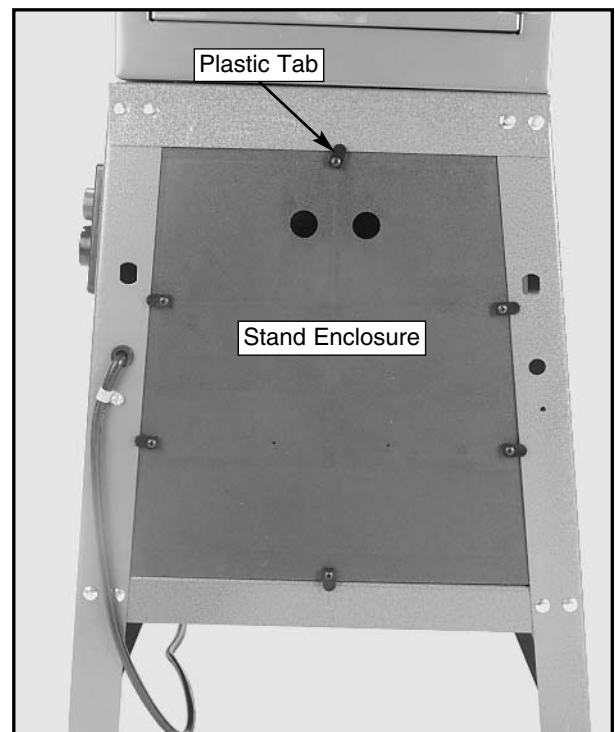

**Figure 9** shows a stand enclosure in place.

**End of Section**

## A. Blade Tension

### To check blade tension:

1. Turn off the power and unplug the saw.
2. Remove the upper wheel guard by removing the black plastic knob. The blade guard will come off with it.
3. Lower the guide post so it is not in the way when testing the tension. This is done by loosening the guide post securing knob. **Figure 11. Do not let the post and attached guide assembly drop. There is no spring attached. Damage could occur.**
4. Press on the face of the blade with your thumb. **Figure 10.**
5. The blade should flex about 1/2" with moderate pressure.

If the blade flexes too much or too little, you will experience problems with blade life and/or cutting efficiency.

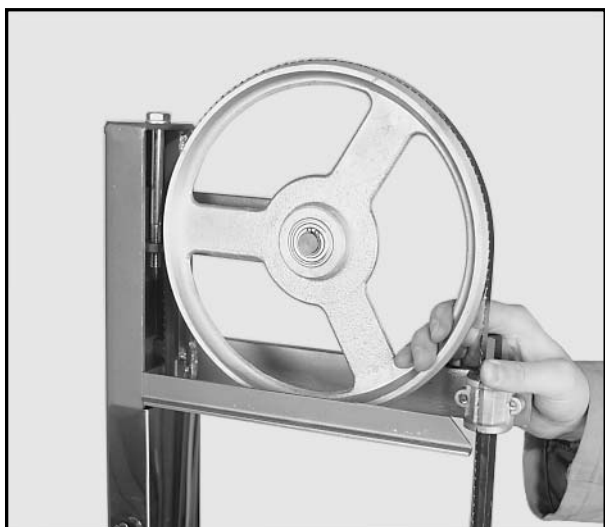

**Figure 10** shows how to test the blade tension.

### To adjust the blade tension:

1. Turn the tension adjustment bolt until the blade appears properly tensioned. **Figure 11.**
2. Check the blade tension again.

*The pressure that the blade puts on the tension bolt acts to keep it in place. The tension should stay relatively constant. But if you find that the blade will not keep proper tension, consider adding a jam nut to the bottom of the tension bolt. This will act as a supplementary lock.*

If the tension seems correct, make the other adjustments to the saw and test run it. If the blade does not cut properly, the tension may be incorrect. Re-adjust tension.

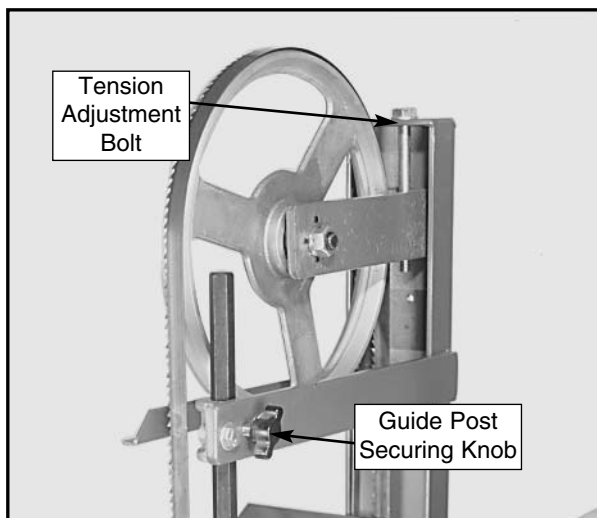

**Figure 11** shows the tension adjustment bolt and the guide post securing knob locations.

**B. Tracking**

Alignment of the blade on the wheels, or tracking, is important for cutting efficiency. Also, blade life will be extended and your cuts will be more predictable.

**To CHECK tracking:**

1. Turn the power off and unplug the saw.
2. Spin the wheels through several complete rotations. Watch the position of the blade on the wheels.
3. The blade will move back and forth on the wheels very slightly. It may also ride closer to the back of the wheels than the front or vice versa. This is acceptable for a meat cutting saw. However, if the blade moves back and forth on the wheels erratically or falls off completely, you must adjust the tracking.

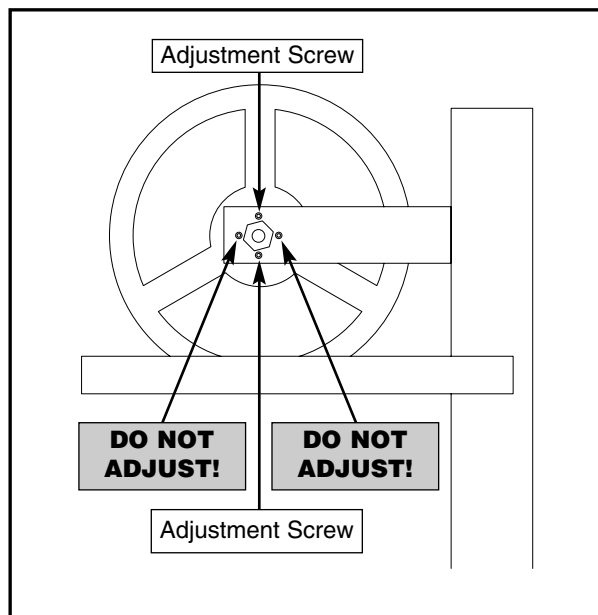

**Figure 12** shows the tracking adjustment screws. *Do not attempt to adjust the horizontally opposed screws.*

**To ADJUST tracking:**

Tracking is adjusted by altering the position of the setscrews behind the upper wheel. **Adjust only the upper and lower setscrews. Do not adjust the setscrews on the sides.** **Figure 12.**

1. Disconnect the bandsaw from the power source and adjust the upper guide blocks away from the blade. See **Section VIII.C.**
2. Decrease the tension slightly before adjusting tracking. Tracking adjustment will automatically increase the tension. See **Section VIII.A.**
3. If you need to push the top of the upper wheel toward the front of the saw, loosen the lower setscrew first and then tighten the upper setscrew.
4. If you need to push the bottom of the upper wheel toward the front of the saw, loosen the upper setscrew first and then tighten the lower setscrew.

Pushing the top or bottom of the upper wheel toward the front of the saw will correct any tracking irregularities. **You must loosen the opposing setscrew before tightening the setscrew that pushes the wheel the way you want. Otherwise, you'll put tremendous pressure on the threads and may strip them out.**



## VIII. Adjustments

3<sup>rd</sup> page of 5 page section

### C. Guide Blocks

The guide blocks ensure that the blade is not pushed too far laterally. The upper guide

blocks are similar to those found on wood cutting bandsaws. The lower guides are steel tabs that can be adjusted to a specific distance from the blade.

#### To adjust the upper guide blocks (Figure 13):

1. Check the position of the guide blocks in relation to the blade. They should be approximately  $\frac{1}{64}$ " behind the gullet line (the low points) of the blade.
2. If the guide blocks are in the correct position, go on to **step 3**. If the guide blocks are out of alignment, you can alter the position of the guide post and guide blocks.
  - a. Loosen the guide post securing knob and remove the entire upper guide post assembly.
  - b. Remove the bolts that anchor the guide post bracket to the frame.
  - c. Add or remove washers between the bracket and the frame to adjust the position of the guide post and the guide blocks. This will correct the position of the guide blocks.
3. Now, loosen the thumbscrews holding the guide blocks in place.
4. Adjust the blocks to about 0.004" from the blade. This is about the same thickness as a piece of typing paper.
5. Re-tighten the thumbscrews.

#### To adjust the lower guide tabs (Figure 14):

1. Remove the table.
2. Note whether the blade touches the fixed plate: it should not. If it does, loosen the nuts that hold the fixed plate in place and position it so the blade is centered in the slot in the fixed plate. Re-tighten the nuts.
3. Loosen the screws that hold the guide tabs in place.
4. Adjust the guide tabs so they are about  $\frac{1}{64}$ " behind the gullet line (the low points) of the blade and 0.004" from the sides of the blade. This is about the same thickness as a piece of typing paper.
5. Re-tighten the screws to secure the tabs.

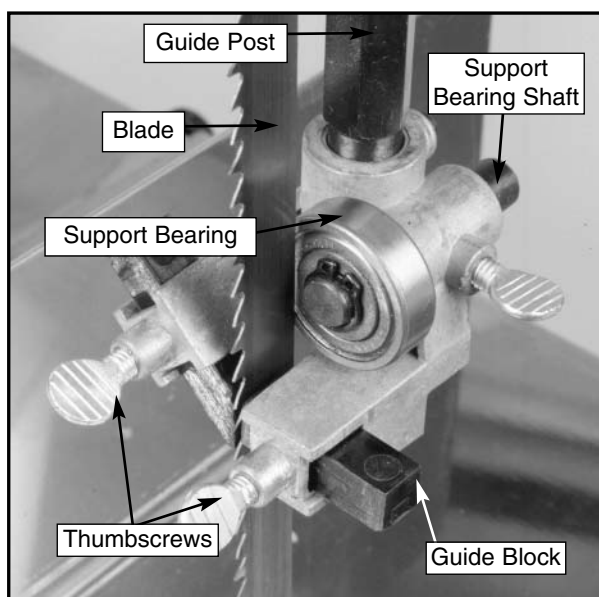

**Figure 13** shows a closeup of the upper guide assembly.

### D. Support Bearings

The support bearings back-up the blade during sawing. The upper support bearing is

located just above the guide blocks. **Figure 13.** The lower support bearing is perpendicular (90°) to the upper bearing, but it should be adjusted similarly.

#### To adjust the upper support bearing (Figure 13):

1. Loosen the thumbscrew securing the upper support bearing shaft.
2. Position the bearing to approximately  $\frac{1}{64}$ " behind the blade.
3. Re-tighten the thumbscrew.

#### To adjust the lower support bearing (Figure 14):

1. Loosen the nut that holds the lower support bearing in place.
2. Position the bearing to approximately  $\frac{1}{64}$ " behind the blade.
3. Re-tighten the nut that holds the bearing in place.

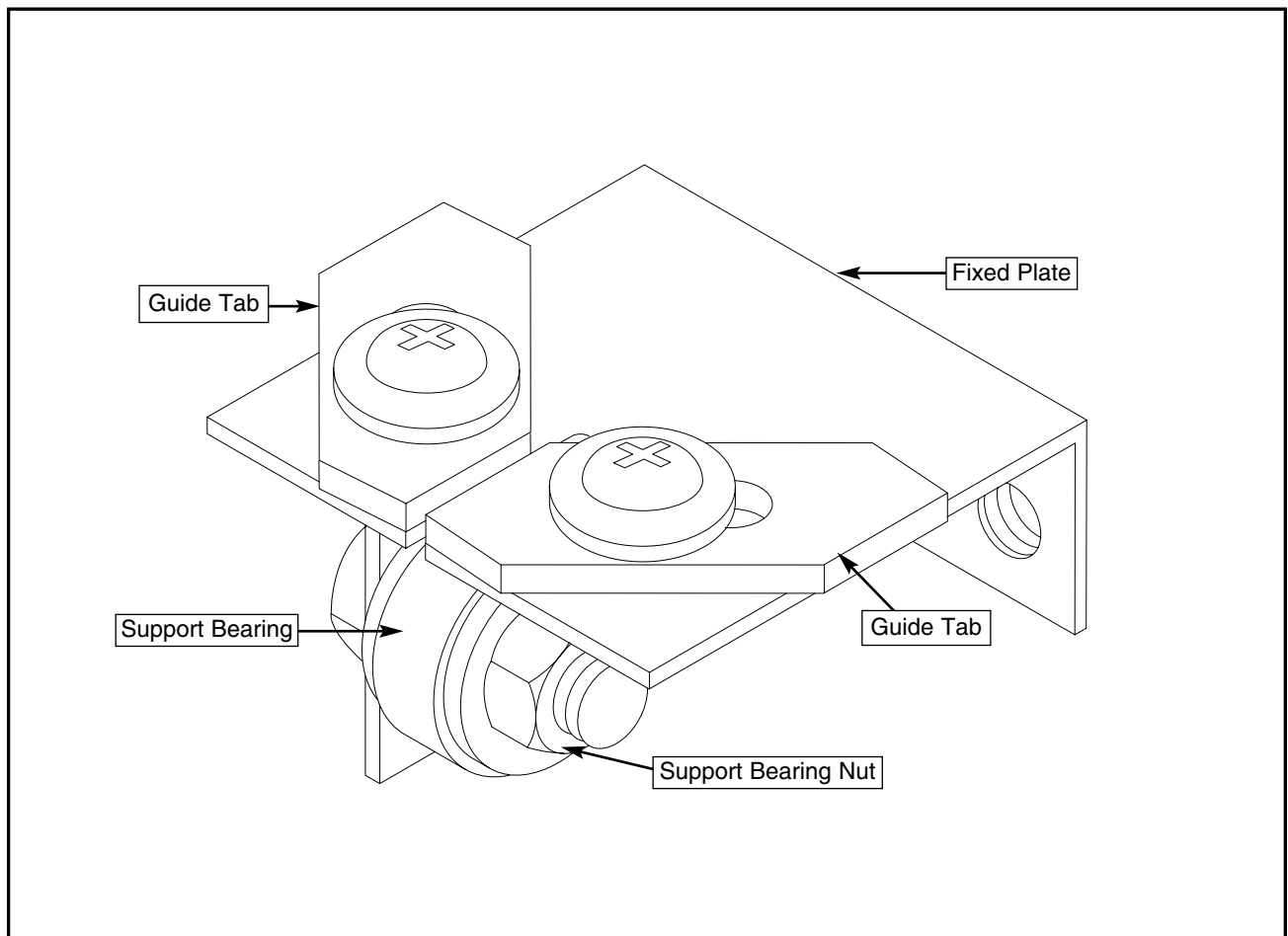

**Figure 14** shows a closeup of the lower guide assembly.

## VIII. Adjustments

5<sup>th</sup> page of 5 page section

### E. Blade Removal and Replacement

#### To remove a blade:

1. Turn off the power and unplug the machine.
2. Remove the table and V-Belt. See **Section VII.D.**
3. Loosen and remove the tension adjustment bolt. Lower the upper wheel mounting arm.
4. Slip the blade off the wheels and pull it out.

#### To install a blade:

1. Turn off the power and unplug the machine. Remove the table and V-Belt.
2. Unscrew the tension adjustment bolt.
3. Lower the upper wheel mounting arm.
4. Slip the blade over both the lower and upper wheels.
5. Carefully lift the upper wheel mounting arm and engage the tension adjustment bolt into the welded nut.
6. Tighten the tension adjustment bolt until the blade is correctly tensioned. Check according to **Section VIII.A.** Check tracking as well. See **Section VIII.B.**

*The teeth must point toward the front of the saw and downward. If you cannot orient the blade so the teeth are in the cutting position, the blade is inside out. Remove the blade, twist it inside out, and replace it. Be sure to check for correct tension and tracking.*

### F. Blade Guard

**Warning:** The blade guard must cover all of the blade above the upper blade guide assembly. It is very dangerous to leave unused portions of the blade exposed.

#### To adjust the blade guard:

1. Loosen the two black knobs that secure the blade guard to the upper wheel guard. **Figure 15.**
2. Slide the blade guard so it almost touches the blade guide assembly.
3. Re-tighten the mounting knobs.

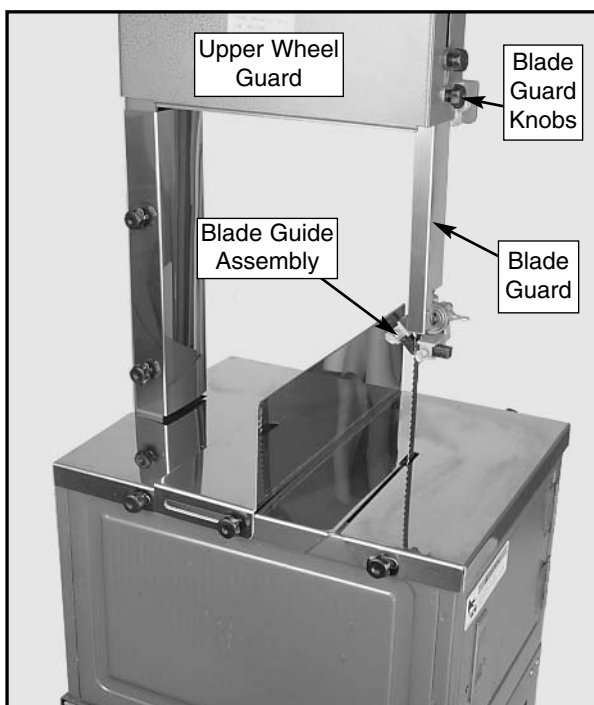

**Figure 15** shows the blade guard in proper position.

End of Section

---

## IX. Safety Rules for Bandsaws

This tool will injure you if you use it in a reckless manner. If you are unfamiliar with the operating and safety procedures for this machine, **DO NOT** use it. Injury prevention begins before the machine is turned on. Please read and observe all safety items addressed in this manual.

We have already discussed general safety rules for all power tools. At this point we wish to review some additional safety items relating specifically to bandsaw operation.

- 
- 1.** Ensure that the machine sits firmly on the floor before use. Any “wobbles” must be corrected **before** operation.
  - 2. ALWAYS** wear eye protection while operating this bandsaw. All safety equipment must be ANSI approved.
  - 3. NEVER** attempt to operate your bandsaw with dull or badly worn blades. Dull blades require more effort to use and are difficult to control. Cracked blades will snap and flail dangerously in the saw during operation. Inspect blades before each use.
  - 4.** This machine is not designed to cut any material other than meat and bone.
  - 5.** All inspections, adjustments, and maintenance are to be done with the power off and the plug pulled from the outlet. Wait for all moving parts to come to a complete stop.
  - 6. DO NOT** operate this bandsaw without wheel and blade guards in place.
  - 7. DO NOT** stick your fingers into the meat grinder
  - 8. NEVER** position body parts in line with the cut.
  - 9. ALWAYS** stand in front (the meat grinder is at the back and the blade teeth point toward the front) of the bandsaw when feeding meat.
  - 10.** Cuts should always be fully supported by the table or some type of support fixture.
  - 11.** Blade should run at full speed before beginning a cut.
  - 12.** When replacing blades, make sure teeth face down toward the table. The force of the cut is always down.
  - 13.** Make sure the blade has proper tension. See **Section VIII.A.**
  - 14. DO NOT** manually stop or slow blade after turning the saw off.
  - 15. DO NOT** operate the bandsaw at excessively low temperatures. Blades can break easier if operated at cold temperatures.
  - 16. NEVER** leave the bandsaw running unattended.

---

End of Section

# X. Operations

---

This bandsaw will make home butchering a simple process. Below is a discussion of possible applications for this saw. Consult your

local butcher shop if you are interested in cutting specific types of steaks or chops.

---

## A. General

- 1. Use a sharp, high-quality blade.**
- 2. Use the right blade for the job.** Your saw comes equipped with a “bone-in” blade - which means it can cut both meat and bone. Do not use a “boneless” blade if planning to cut through bone.
- 3.** Partially frozen meat is easier to cut than meat at room temperature. At room temp, the meat is so soft that it will tend to plug the grinder and blade.
- 4. Allow the saw to cut. Don't force the meat into the blade.** Feed the blade with even pressure at a moderate speed.
- 5. Maintain your bandsaw in top condition.** See **Section XII** of this manual for maintenance procedures.

## B. Test Run

- 1.** Completely assemble the bandsaw and perform all adjustment procedures.
- 2.** Check that all fasteners are tight.
- 3.** Make sure that the saw is properly wired for the voltage you intend to use.
- 4.** Turn on the machine. Be ready to turn it off immediately if there is any sign of malfunction.
- 5.** If everything is normal, proceed to **Part C** and begin cutting.

## C. Cutting Procedures

- 1.** Determine the steak thickness you want.
- 2.** Position the fence according to steak thickness. If not using the fence, remove it completely. *Removing the fence means one less item to clean.*
- 3.** Adjust the upper blade guide assembly so it is 1/4" from the top of your meat. Adjust the blade guard so it covers any unused portion of the blade.
- 4.** Set up a large bowl or container to place your steaks as they are cut. Package them when you are finished cutting.
- 5.** Power up and let the saw reach full speed.
- 6.** Feed your meat into the blade slowly and evenly. ***Do not allow your fingers to come close to the blade.*** Retrieve your steaks and put them in your bowl or container.

## D. Meat Grinder

The meat grinder operates simultaneously with the blade. As you are cutting steaks, any extra pieces can be put into the meat grinder. If you are using the grinder only, remove the blade to decrease the hazards.

Optional dies (parts #33A and #33B) are available for a small fee. Consult the parts list and service department for more information.

You can also make sausages by putting sausage casing over the casing tube and forcing the meat into it. Consult your butcher for further instructions about making sausage.

---

End of Section

---

## XI. Cleaning

### ***Your meat cutting band-saw MUST be thoroughly cleaned after each use!***

Bacterial infection is a major concern when working with raw meat. Your meat cutting bandsaw must be thoroughly cleaned with antibacterial soap and water or bleach and water after each use.

Fortunately, your saw was designed with these requirements in mind. A thorough cleaning can be performed relatively easily.

#### **To clean your bandsaw:**

1. Turn the power off and unplug the saw.
2. Remove the table, fence, upper wheel guard with blade guard, and column guard. Wash them thoroughly.
3. Pull the V-Belt off the pulleys (**Section VII.D.**) and clean it. **Use soap and water only.**
4. Unscrew the threaded studs that anchor the saw to the stand and remove the saw. **The motor is not sealed. Do not allow water to contact it.** Take the saw to a place where you can thoroughly hose off any meat remnants and do so.
5. Thoroughly wash the saw with antibacterial soap or bleach. Do not forget to clean the blade. *Soap is cheap, lather it up.*
6. Rinse the saw off with the hose and dry it. Some parts, such as the blade, will rust if not dried completely. *Wiping the blade with vegetable oil will help to retard rust.*

7. Remove the enclosures from the sides of the stand. Clean out any spots that have been contacted by meat. Pay particular attention to the motor pulley. *Be careful not to let water get down into the motor.*
8. Re-assemble the bandsaw in the opposite order it was taken apart.

*Do not neglect to clean your saw immediately after use. By cleaning it immediately, you will avoid bacteria, rust, stinky, rotten meat chunks, and a host of other problems.*

#### **To clean the meat grinder:**

Remove the meat grinder from the saw by loosening the mounting bolt and pulling the grinder off. Completely disassemble the grinder and clean it with antibacterial soap and water or bleach and water. When re-assembling, be sure to orient the blade correctly. The grinder will not grind effectively if the grinder blade is fitted backward. When the meat exits the auger, it should contact the flat, sharp side of the grinder blade – not the round, blunt side. **Figure 16.**

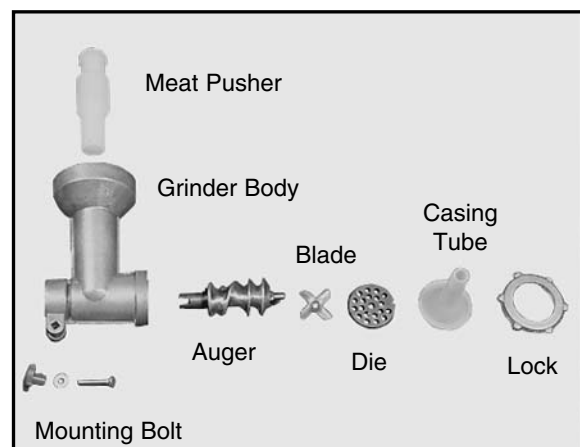

**Figure 16** shows the meat grinder disassembled for cleaning.

---

**End of Section**

## **XII. Maintenance**

---

Since the moving parts on this machine run on shielded ball bearings, you will find that there is very little in the line of routine maintenance outside of cleaning (See **Section XI**). However, "little maintenance" does not imply "no maintenance." This section will cover a few simple but crucial steps for the proper maintenance of your bandsaw.

### **A. Lubrication**

Shielded and pre-lubricated ball bearings require no extra lubrication for the life of the bearings. All bearings are standard sizes. If they wear out, replacements can be easily purchased from our parts department or bearing supply stores.

As for other items on this machine, such as adjustment controls, an occasional "shot" of light oil is just about all that is necessary. Before applying, however, wipe off any debris with a clean cloth or towel and spray on the lubricant. Ensure that oil does not get on the pulleys or V-Belts because it could cause belt deterioration and slipping. Wipe off any spray that gets on the blade, meat grinder, or any stainless steel cutting surfaces.

### **B. Miscellaneous**

Always be aware of the condition of your bandsaw before using it. Routinely check the condition of the following items and repair or replace as necessary.

- 1.** Loose mounting bolts.
- 2.** Worn switch.
- 3.** Worn or damaged blade.
- 4.** Worn or damaged support bearings or guide blocks.
- 5.** Worn or damaged V-Belt.
- 6.** Any other condition that may affect safe operation of this machine.

---

**End of Section**

## XIII. Troubleshooting

<b>SYMPTOM</b>	<b>POSSIBLE CAUSE</b>	<b>CORRECTIVE ACTION</b>
Motor will not start.	<ol style="list-style-type: none"> <li>1. Low voltage.</li> <li>2. Open circuit in motor or loose connections.</li> <li>3. Worn or defective switch.</li> <li>4. Faulty starting capacitor.</li> <li>5. Centrifugal switch out of adjustment.</li> </ol>	<ol style="list-style-type: none"> <li>1. Check power line for proper voltage.</li> <li>2. Inspect all lead connections on motor for loose or open connections.</li> <li>3. Check voltage at motor junction box.</li> <li>4. Replace capacitor.</li> <li>5. Contact customer service for further instructions.</li> </ol>
Motor will not start; fuses or circuit breakers blow.	<ol style="list-style-type: none"> <li>1. Short circuit in line cord or plug.</li> <li>2. Short circuit in motor or loose connections.</li> <li>3. Incorrect fuses or circuit breakers in power line.</li> </ol>	<ol style="list-style-type: none"> <li>1. Inspect cord or plug for damaged insulation and shorted wires.</li> <li>2. Inspect all connections on motor for loose or shorted terminals or worn insulation.</li> <li>3. Install correct fuses or circuit breakers.</li> </ol>
Motor fails to develop full power (power output of motor decreases rapidly with decrease in voltage at motor terminals).	<ol style="list-style-type: none"> <li>1. Power line overloaded with lights, appliances, and other motors.</li> <li>2. Undersized wires or circuits too long.</li> <li>3. General overloading of power company facilities.</li> </ol>	<ol style="list-style-type: none"> <li>1. Reduce load on power line.</li> <li>2. Increase wire sizes or reduce length of wire.</li> <li>3. Request a power check from the power company.</li> </ol>
Motor overheats.	<ol style="list-style-type: none"> <li>1. Motor overloaded.</li> <li>2. Air circulation through the motor restricted.</li> </ol>	<ol style="list-style-type: none"> <li>1. Reduce load on motor.</li> <li>2. Clean out motor to provide normal air circulation.</li> </ol>
Motor stalls (resulting in blown fuses or tripped circuit).	<ol style="list-style-type: none"> <li>1. Short circuit in motor or loose connections.</li> <li>2. Low voltage.</li> <li>3. Incorrect fuses or circuit breakers in power line.</li> <li>4. Motor overloaded.</li> </ol>	<ol style="list-style-type: none"> <li>1. Inspect connections on motor for loose or shorted terminals or worn insulation.</li> <li>2. Correct the low voltage conditions.</li> <li>3. Install correct fuses or circuit breakers.</li> <li>4. Reduce load on motor.</li> </ol>
Machine slows when using.	Applying too much pressure.	Feed slower.
Blade does not run evenly on wheels or runs off.	Tracking is not adjusted properly.	Adjust tracking.
Blade slows when cutting. Blade makes a squealing noise, especially on start up.	<ol style="list-style-type: none"> <li>1. V-Belt loose.</li> <li>2. V-Belt worn out.</li> </ol>	<ol style="list-style-type: none"> <li>1. Tighten V-Belt.</li> <li>2. Replace V-Belt.</li> </ol>



# XIV. Main Parts Diagram

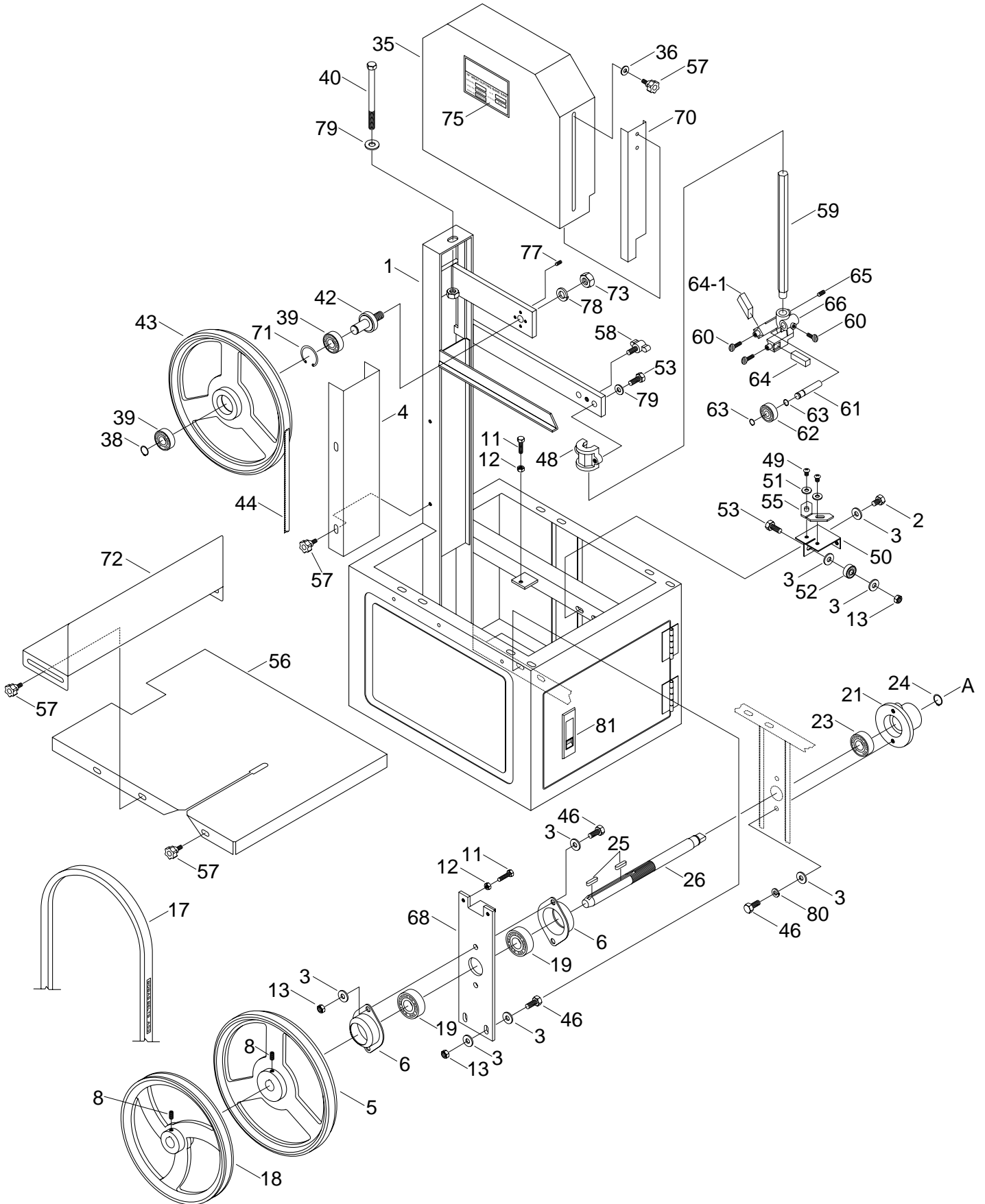

# XV. Meat Grinder Parts Diagram

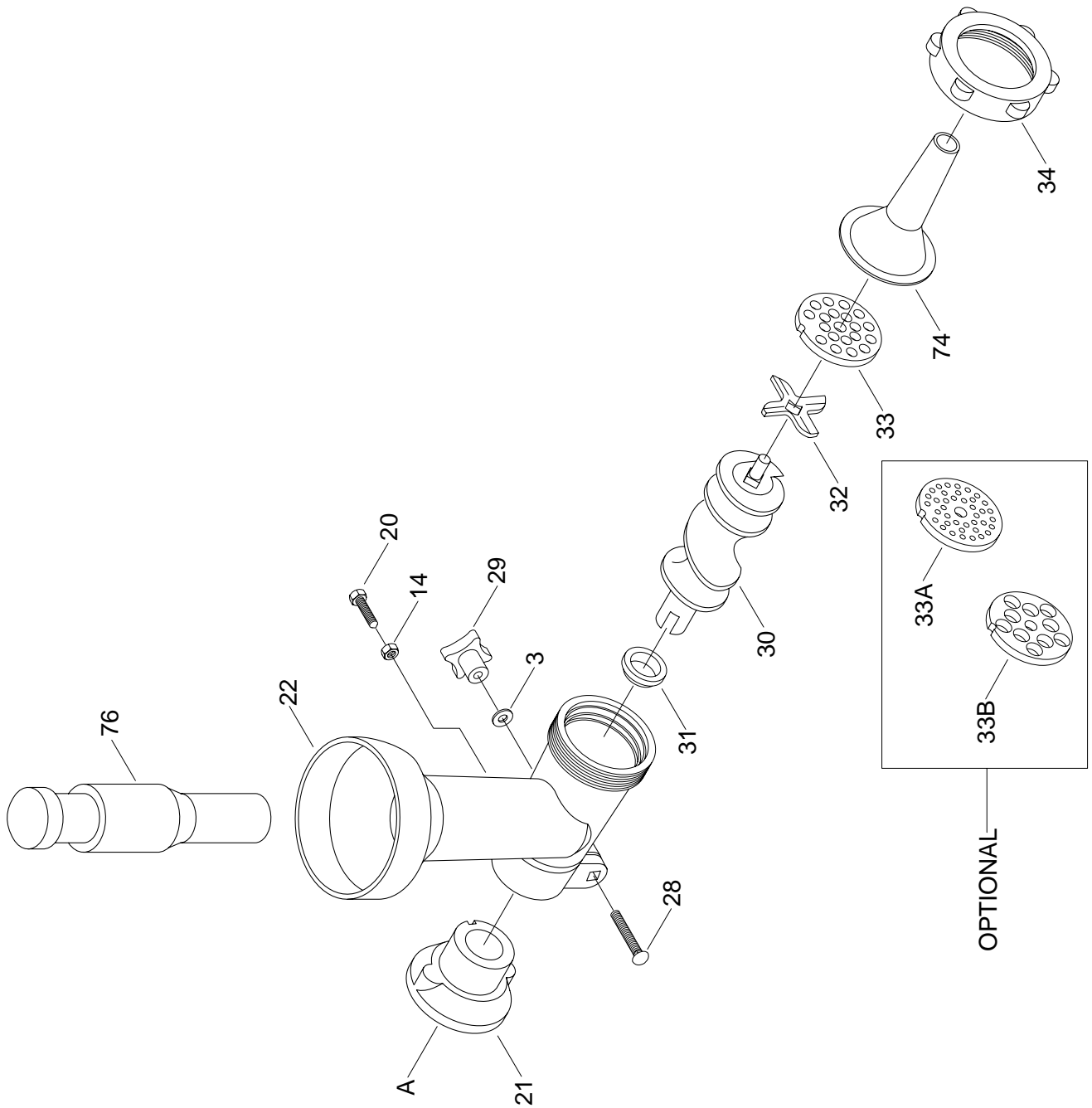

# XVI. Stand Parts Diagram

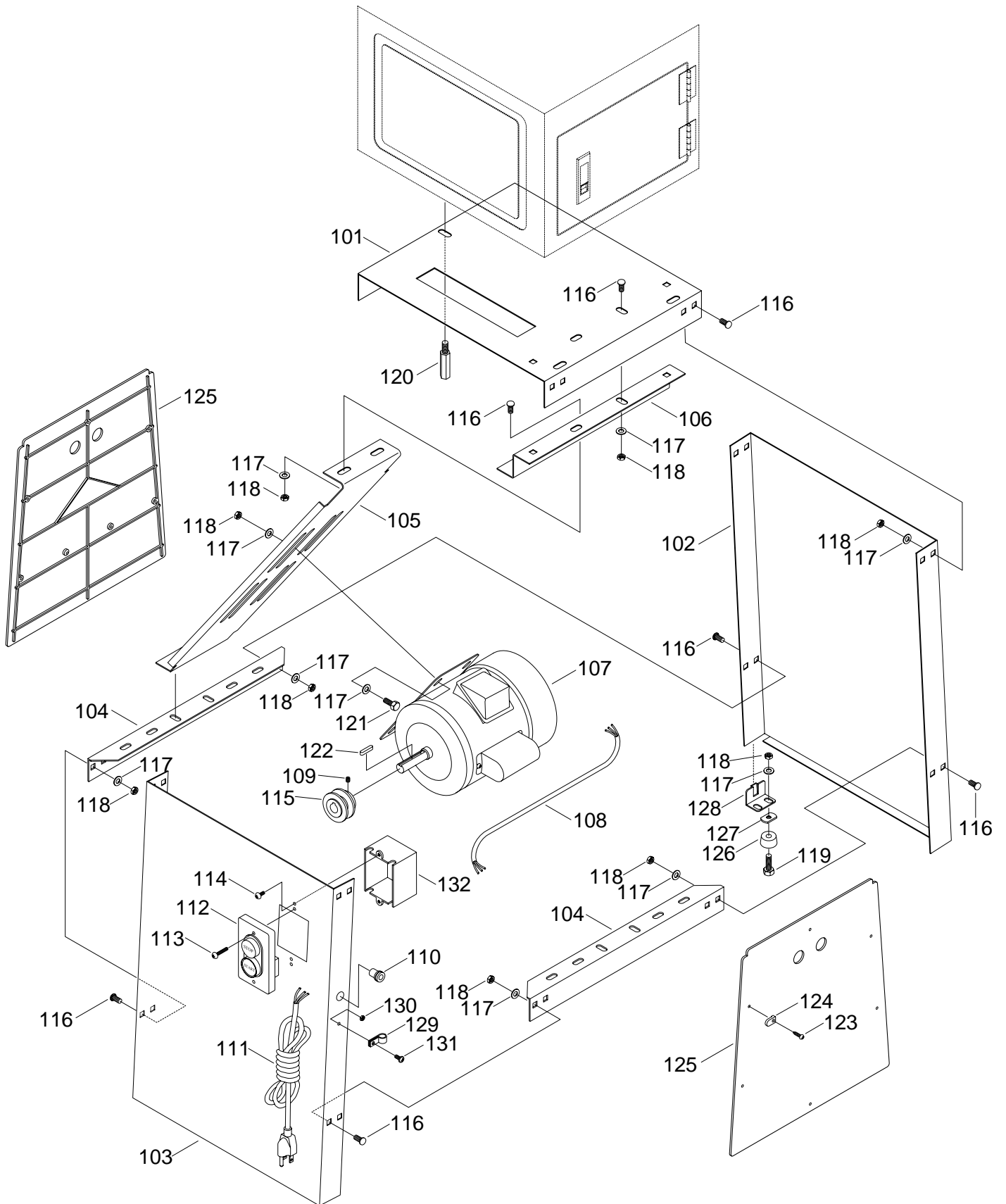

## XVII. Parts List

REF#	PART#	DESCRIPTION	REF#	PART#	DESCRIPTION
001	P1016001	CABINET BODY	061	P1016061	BEARING GUIDE SHAFT
002	PB09	HEX BOLT 5/16" - 18 x 1/2"	062	P6000	BEARING 6000-2RS
003	PW07	FLAT WASHER 5/16"	063	PR01M	SNAP RING 10mm
004	P1016004	COVER	064	P1016064	GUIDE BLOCK
005	P1016005	LOWER WHEEL	64-1	P1016064-1	GUIDE BLOCK
006	P1016006	BEARING MOUNT	065	PSS01M	SETSCREW M6 - 1.0 x 10
008	PSS04M	SETSCREW M6 - 1.0 x 12	066	P1016066	BLADE GUIDE COVER
011	PB08M	HEX BOLT M6 - 1.0 x 20	068	P1016068	LOWER SHAFT MOUNT
012	PN01M	HEX NUT M6 - 1.0	070	P1016070	BLADE GUARD
013	PN02	HEX NUT 5/16" - 18	071	PR21M	SNAP RING 35mm
014	PN01M	HEX NUT M6 - 1.0	072	P1016072	FENCE
017	PVA53	V-BELT A-53	073	PN06	HEX NUT 1/2" - 12
018	P1016018	PULLEY	074	P1016074	CASING TUBE
019	P6204	BEARING 6204-2RS	075	P1016075	NAME PLATE
020	PB08M	HEX BOLT M6 - 1.0 x 20	076	P1016076	PESTLE
021	P1016021	BRACKET	077	PSS05M	SETSCREW M5 - 0.8 x 10
022	P1016022	GRINDER BODY	078	PLW07	LOCK WASHER 1/2"
023	P6203	BEARING 6203-2RS	079	PW02	FLAT WASHER 3/8"
024	PR18M	SNAP RING 17mm	080	PLW01	LOCK WASHER 5/16"
025	PK01M	KEY 5 x 5 x 22mm	081	P1016081	DOOR LATCH ASSEMBLY
026	P1016026	SHAFT	101	P1016101	TOP PANEL
028	P1016028	CARR BOLT 5/16" - 18 x 1 3/4"	102	P1016102	REAR PANEL
029	P1016029	LOCK KNOB	103	P1016103	FRONT PANEL
030	P1016030	AUGER	104	P1016104	BRACE
031	P1016031	BUSHING	105	P1016105	MOTOR MOUNT PLATE
032	P1016032	BLADE	106	P1016106	AUXILIARY MOTOR BRACKET
033	P1016033	DIE (8mm)	107	P1016107	MOTOR 1HP
33A	P1016033A	DIE	108	P1016108	CORD, MOTOR TO SWITCH
33B	P1016033B	DIE	109	PSS02M	SETSCREW M6 - 1.0 x 6
034	P1016034	LOCK	110	P1016110	STRAIN RELIEF
035	P1016035	TOP WHEEL COVER	111	P1016111	POWER CORD
036	PW06	FLAT WASHER 1/4"	112	P1016112	SWITCH
038	PR02M	SNAP RING 14mm	113	PS03	PHLP HD SCREW 10 - 24 x 1"
039	P6202	BEARING 6202-2RS	114	PS06	PHLP HD SCREW 10 - 24 x 3/8"
040	PB08	HEX BOLT 3/8" - 16 x 5	115	P1016115	MOTOR PULLEY
042	P1016042	UPPER WHEEL SHAFT	116	PCB02	CARRIAGE BOLT 5/16" - 18 x 1/2"
043	P1016043	TOP BLADE WHEEL	117	PW07	FLAT WASHER 5/16"
044	G1098	SEE CATALOG	118	PN02	HEX NUT 5/16" - 18
046	PB07	HEX BOLT 5/16" - 18 x 3/4"	119	PB03	HEX BOLT 5/16" - 18 x 1"
048	P1016048	GUIDE POST BRACKET	120	P1016120	SPECIAL BOLT
049	PS07	PHLP HD SCRW 1/4" - 20 x 3/8"	121	PB07	HEX BOLT 5/16" - 18 x 3/4"
050	P1016048	GUIDE POST BRACKET	122	PK23M	KEY 5 x 5 x 25mm
051	PW06	FLAT WASHER 1/4"	123	P1016123	SCREW
052	P608	BEARING 608-2RS	125	P1016125	PLASTIC SIDE PANEL
053	PB07	HEX BOLT 5/16" - 18 x 3/4"	126	P1016126	RUBBER FOOT
055	P1016055	LOWER GUIDE	127	P1016127	KEEPER
056	P1016056	TABLE	128	P1016128	MOUNT BRACKET
057	P1016057	KNOB	129	P1016129	WIRE CLAMP
058	P1016058	LOCK KNOB	130	PN07	HEX NUT 10 - 24
059	P1016059	GUIDE POST	131	PS01	PHLP HD SCREW 10 - 24 x 1/2"
060	P1016060	THUMB SCREW	132	P1016132	SWITCH COVER

# XVIII. Machine Data

---

## HUNTER'S MEAT CUTTING SAW

Design Type .....2 Wheel Floor Model

### Overall Dimensions:

Table .....16" W x 13<sup>3</sup>/<sub>8</sub>" D  
Stand .....23<sup>1</sup>/<sub>2</sub>" H x 16" W x 18" D  
Height .....58"  
Height from Floor to Table .....34<sup>1</sup>/<sub>2</sub>"  
Width of Unit .....16"  
Shipping Weight .....106 lbs.

### Cutting Capacity:

Left of Blade .....9<sup>3</sup>/<sub>4</sub>"  
Height .....10<sup>1</sup>/<sub>4</sub>"  
Blade Speed .....1125 FPM  
Grinder Speed .....45 RPM

### Construction:

Table .....Stainless Steel  
Wheels .....Aluminum  
Fence .....Die Stamped  
Wheel Covers .....Pre-Formed Steel  
Guides .....Fiber Blocks with Thrust Ball Bearings

### Motor:

Type .....TEFC Capacitor Start Induction  
Horsepower .....1 HP  
Phase/Cycle .....Single Phase/60 Hz  
Voltage .....110V  
Amps .....16A  
RPM .....1720  
Bearings .....Shielded and Permanently Lubricated Ball  
Switch .....On/Off Mechanical

### Features:

Includes Blade, Meat Grinder, and Casing Tube

*Specifications, while deemed accurate, are not guaranteed.*

## **Limited Warranty & Returns Policy**

Grizzly Imports, Inc. warrants every product it sells for a period of **1 year** to the original purchaser from the date of purchase. This warranty does not apply to defects due directly or indirectly to misuse, abuse, negligence, accidents, repairs or alterations or lack of maintenance. This is Grizzly's sole written warranty and any and all warranties that may be implied by law, including any merchantability or fitness, for any particular purpose, are hereby limited to the duration of this written warranty. We do not warrant or represent that the merchandise complies with the provisions of any law or acts unless the manufacturer so warrants. In no event shall Grizzly's liability under this warranty exceed the purchase price paid for the product and any legal actions brought against Grizzly shall be tried in the State of Washington, County of Whatcom.

We shall in no event be liable for death, injuries to persons or property or for incidental, contingent, special, or consequential damages arising from the use of our products.

To take advantage of this warranty, contact us by mail or phone and give us all the details. We will then issue you a "Return Number" which must be clearly posted on the outside as well as the inside of the carton. We will not accept any item back without this number. Proof of purchase must accompany the merchandise.

The manufacturers reserve the right to change specifications at any time because they constantly strive to achieve better quality equipment. We make every effort to ensure that our products meet high quality and durability standards and we hope you never need to use this warranty.